

LINK BOX CHAMBER PLAN
SCALE 1:20

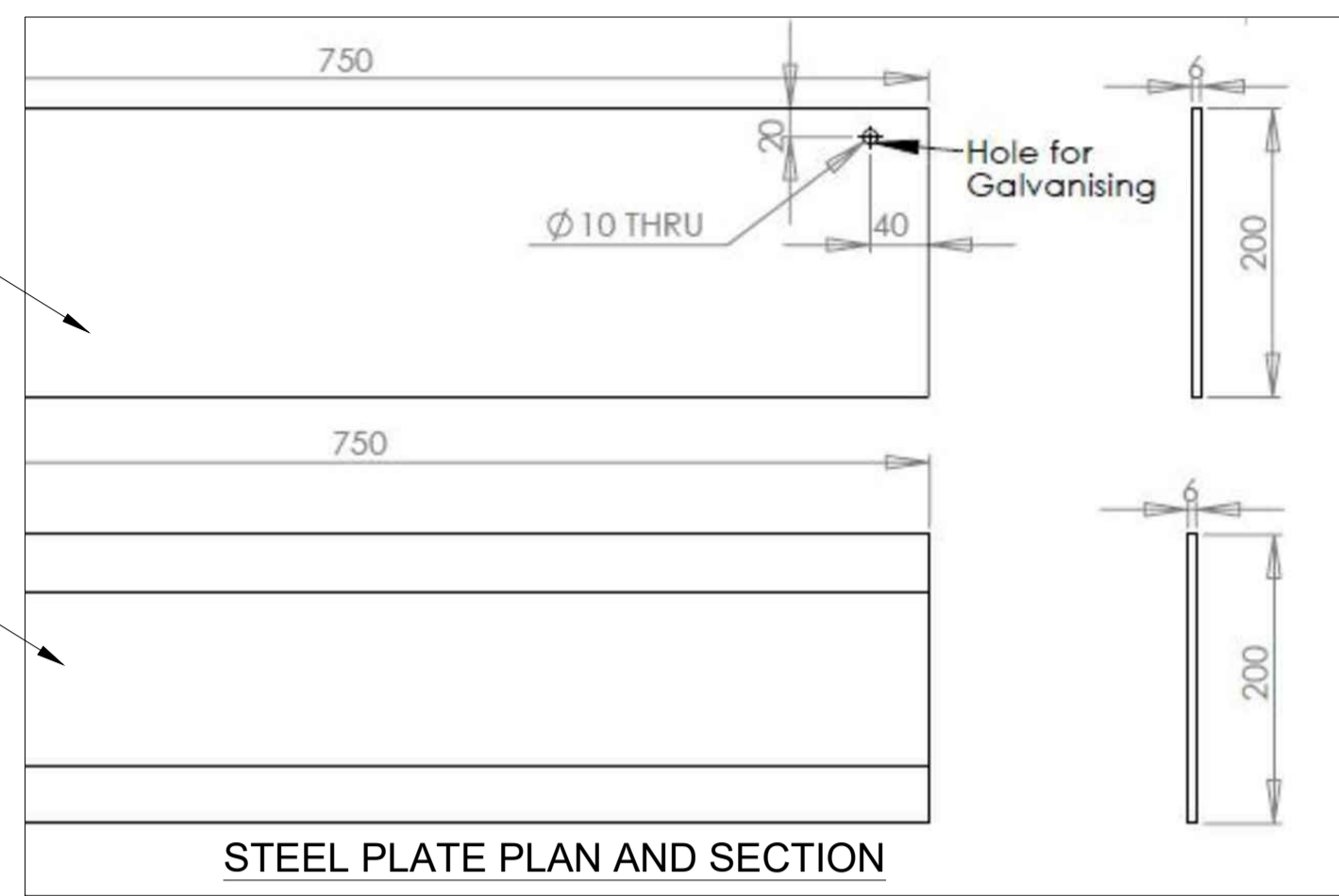

STEEL PLATE PLAN AND SECTION
NTS

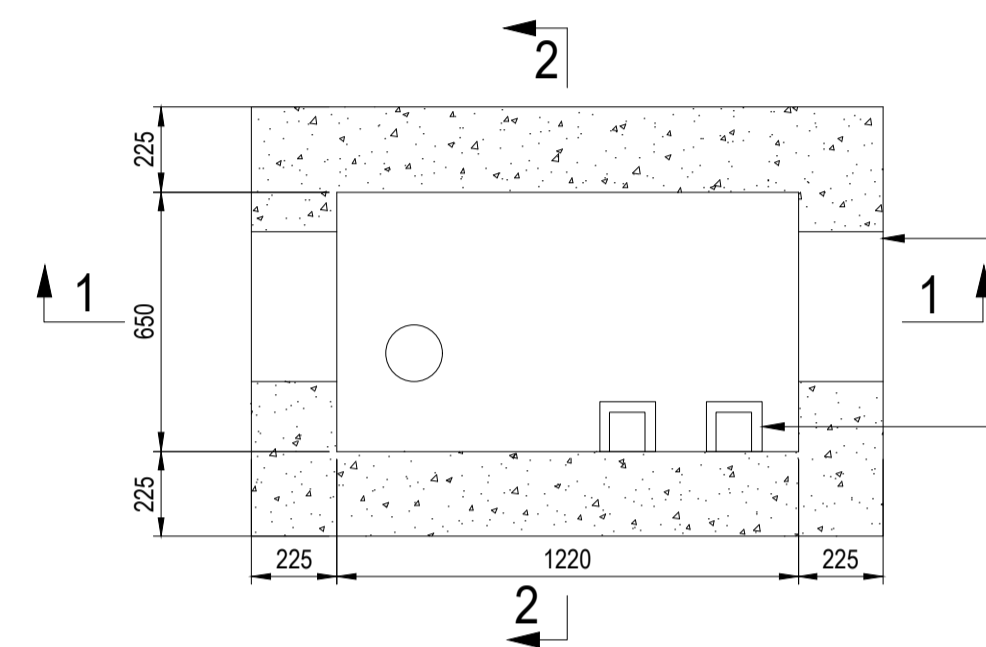

COMMUNICATION CHAMBER PLAN
COVER, FRAME & DUCTS OMITTED FOR CLARITY
SCALE 1:20

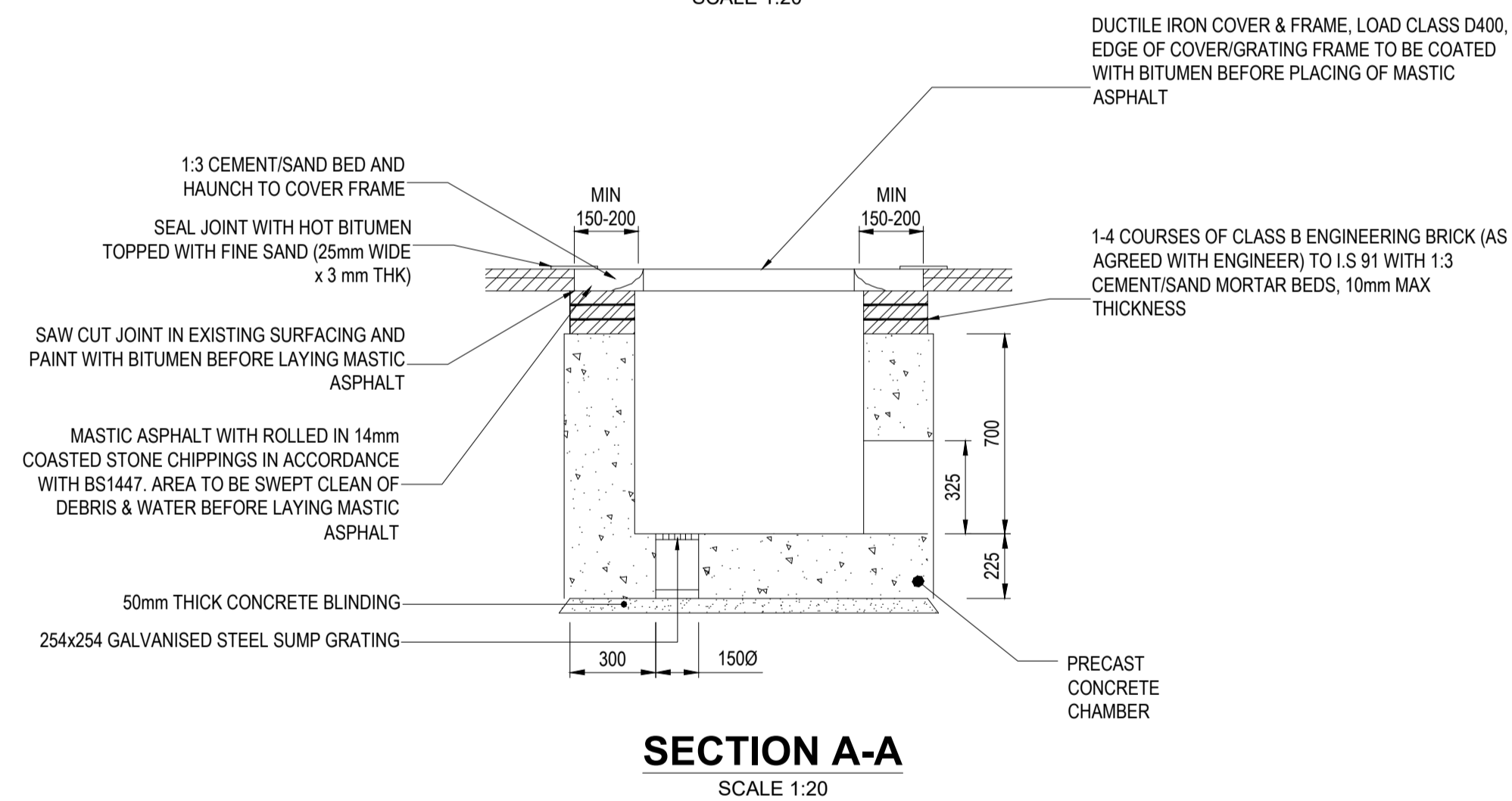

SECTION A-A
SCALE 1:20

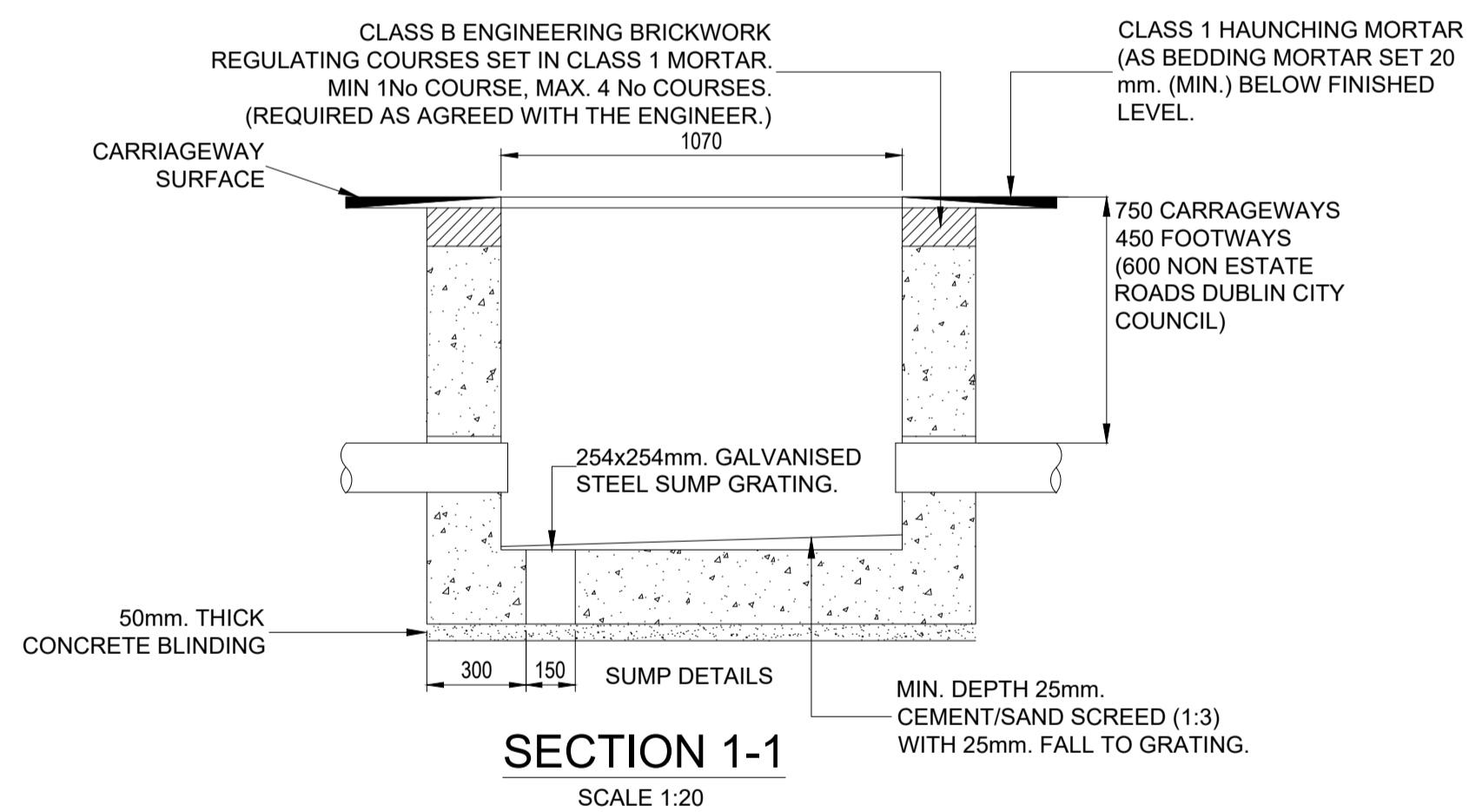

SECTION 1-1
SCALE 1:20

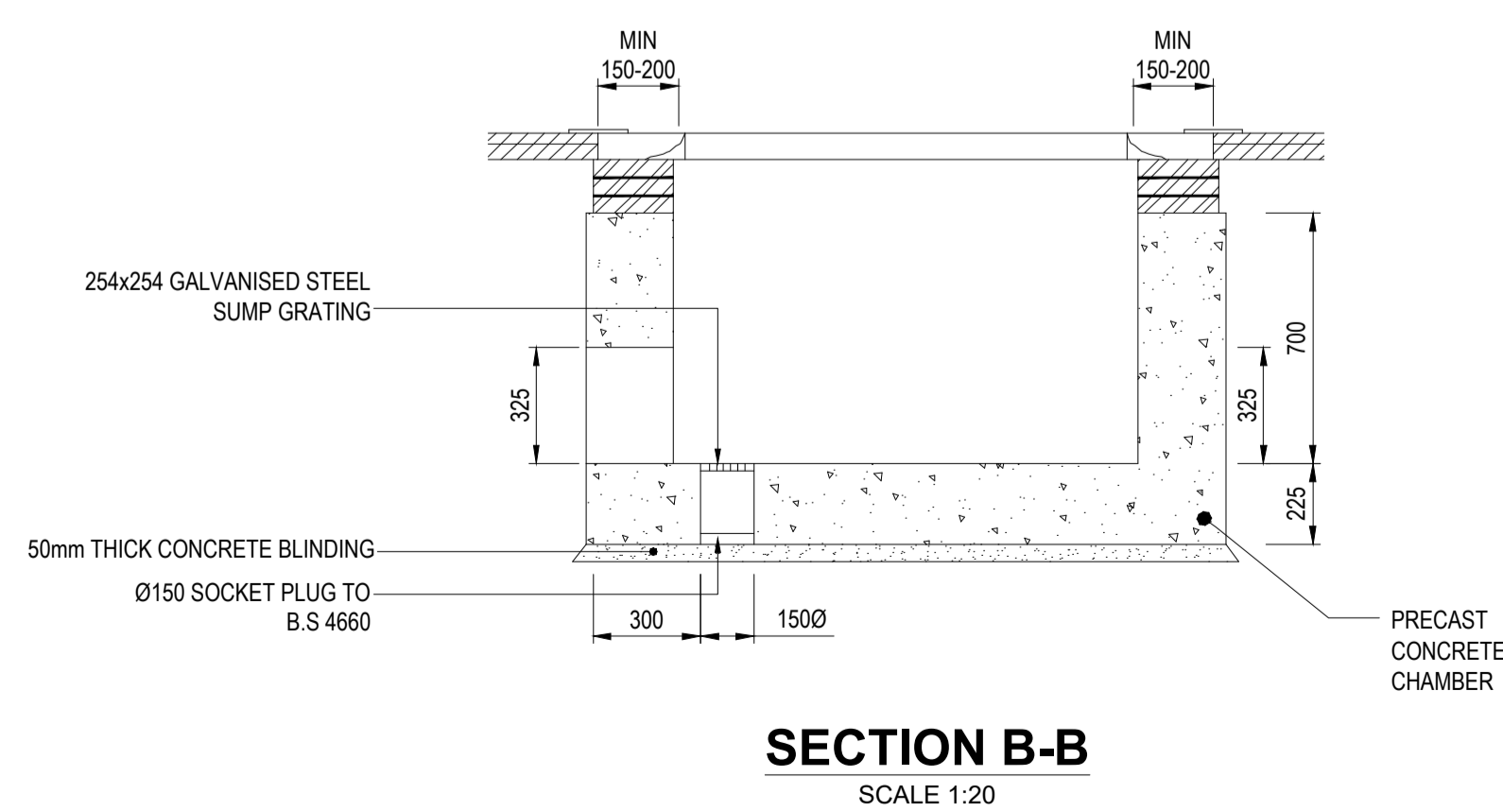

SECTION B-B
SCALE 1:20

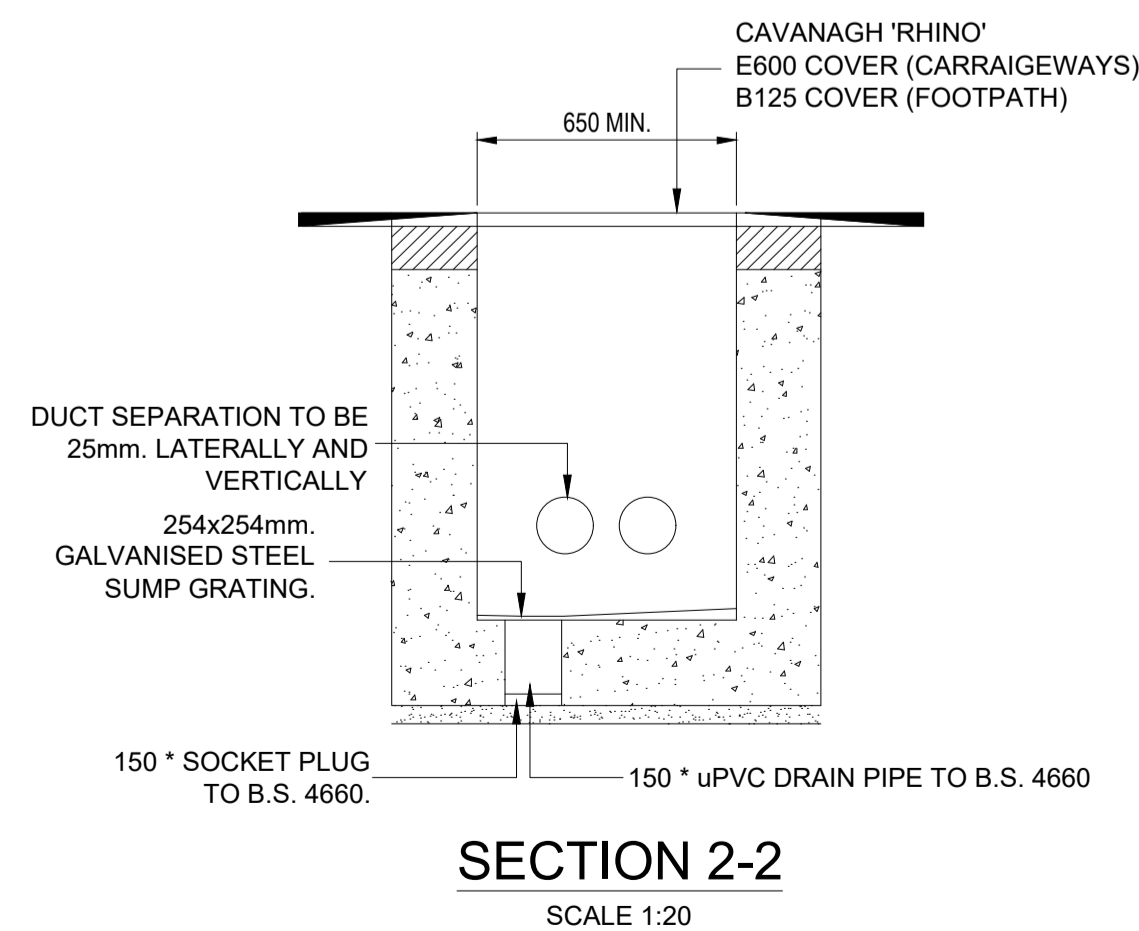

SECTION 2-2
SCALE 1:20

Rev	Description	Drawn	Checked	Date
P04	SID ISSUE	DM	PM	04.02.2022
P03	DRAFT SID ISSUE	DM	PM	10.12.2021
P02	SID SCHEME ISSUE	DM	PM	26.11.2021
P01	WIP	DM	PM	22.10.2021

Clifton Scannell Emerson Associates
Clifton Scannell Emerson Associates Limited
Consulting Engineers,
3rd Floor The Highline,
Bakers Point, Pottery Road,
Dun Laoghaire, Co. Dublin,
Ireland, A96 KW29
T. +353 1 288 5006
F. +353 1 283 3466
E. info@csea.ie
W. www.csea.ie

VANTAGE DATA CENTERS

Client: **KILCABERY 110KV SUBSTATION & MV CLIENT COMPOUND**

Project: **TYPICAL DETAILS FOR LINK BOXES, C2 CHAMBERS & STEEL PLATES**

Dwg. Title: **21_115**

Drawn By: **DM** Date: **OCT 2021**

Checked By: **PM** Scale: **AS INDICATED @ A1**

Project Code: **21_115 - CSE - 00 - XX - DR - C - 1261**

Status Code: **S2** Suitability Description: **PRELIMINARY**

Revision: **P04** Project Status: **PRELIMINARY**